

MECARING

Boost your performance.



// In automatic robot packaging, MECARING units significantly reduce manual workload. Increased efficiency and shorter turnaround times guarantee high-quality end products for our customers.

Harri Mikkola, Production manager, Uponor infra

Extron MECARING makes automatic seal inserting easy and effective. Our unique design is flexibly integrated with your production line. MECARING offers you optimal tools for pipe fitting with various sealing rings. Automated system reduces errors, enhances effectivity and provides your professionals with an easy and comfortable user experience.

STREAMLINE RESOURCES AND REDUCE ERRORS

Automated seal inserting boosts your production, enhances ergonomics and releases operators to more valuable work. Your customers can be sure that the necessary seals will come with delivery.

FLEXIBLE TO OPERATE

MECARING units are optimized to match your production needs. Versatile layout design and compact size ensure flexible and safer working environment.

QUICK CHANGEOVER & EASY TO USE

Changing the tool for different seal type and ring diameter is quick and easy. The unit is controlled by a touch screen, so it is comfortable to use and the settings can be precisely customized.

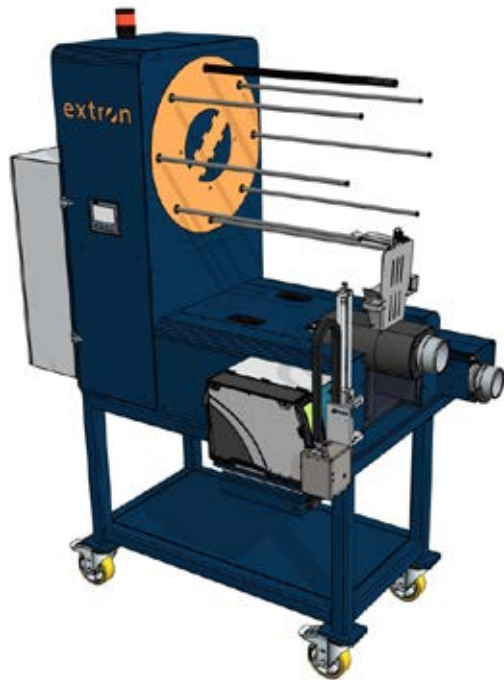

MECARING A

MECARING A is designed to boost your process with automatic seal inserting. It is easy to integrate to pipe extrusion and injection molding lines. It is effective for both online and offline use.

FEATURES:

- Pipes and fittings from 32 to 200 mm
- For variable seal types (mm, inch)
- Application speed up to 800 pcs/h
- Large-capacity seal magazine, up to 400 pcs
- Various inserting tools with only 5 min changeover time
- Controlled by Siemens PLC with touch screen
- Connected to **Extron VASTE** Cloud Service

TECHNICAL SPECIFICATIONS:

- Overall machine dimensions 1100 x 660 x 1250 mm
- Compressed air connection: Inlet 0.5 inches, minimum operating pressure 6 bar
- Electrical connection 400/230 VAC, 16 A

OPTIMIZE YOUR MECARING A WITH EASY-CHANGE INSERTING TOOLS FOR A WIDE RANGE OF SEALS

MECATOOL BL

- Available from 32 mm to 200 mm (inch sizes available)
- Sewer and Duct pipe seals, such as BL etc.
- Compresses the seal for inserting, needs low lubrication
- Pneumatic operation with one cylinder

MECATOOL DD

- Available from 40 mm to 160 mm (also inch sizes)
- Sewer pipe seals, such as HMS and DD types etc.
- Slides the seal through the cylindrical tool, needs lubrication
- Pneumatic operation with two cylinders

MECATOOL FS

- Available from 50 mm to 200 mm (also inch sizes)
- Pressure and non-pressure pipe seals, such as HB-Fix, Din Lock, Anger Lock, Rieber etc.
- Simulates the human way of mounting, no lubrication needed
- Pneumatic operation with four cylinders

Ask for bigger diameters (up to 400 mm) for special solutions.

Optional add-ons:

- Quality control unit for seal installation and fitting quality
- Label applicator with printer

extron
architects of extrusion

Taluttatie 4
FI-37800 Akaa, Finland
tel. +358 40 172 7391
info@extron.fi

MECARING DW

MECARING DW is designed to boost your process with automatic external seal inserting. It is easy to integrate to corrugated pipe extrusion line. It is effective for both online and offline use.



FEATURES:

- For corrugated pipes OD 110 to 250 mm. Special projects for bigger ones.
- Pipe lengths starting from 2 m
- For flexible rubber seals in several profiles
- Application speed up to 150 gaskets per hour
- Large-capacity seal magazine, up to 360 seals
- Special designed tools for each seal type and diameter
- Macatool DW available for every standard mm/inch size
- Tool changeover and machine setting time less than 15 minutes
- Connected to Extron VASTE Cloud Service
- Interface for extrusion line control system
- Flexible operating modes: pipe through machine or pipe in-out

TECHNICAL SPECIFICATIONS:

- Overall machine dimensions: 2000 x 1700 x 2100 mm
- Pipe center heights 1000 mm (adjustable)
- Compressed air connection: Inlet 1/2", minimum operating pressure 6 bar
- Electrical connection 400/230 VAC, 16 A

extron
architects of extrusion

Taluttatie 4
FI-37800 Akaa, Finland
tel. +358 40 172 7391
info@extron.fi



MECARING M

MECARING M is designed to boost your process with automatic seal inserting. Compact footprint - easy to integrate to injection molding units.

FEATURES:

- Fittings from 32 to 200 mm
- For variable gasket types (mm, inch)
- Application speed up to 800 pcs/h
- Seal magazine, up to 200 pcs

TECHNICAL SPECIFICATIONS:

- Overall machine dimensions based on chosen seal size from 400 x 400 x 1200 mm to 700 x 500 x 1400 mm
- Compressed air connection: Inlet 0.5", min. operating pressure 6 bar
- Electrical connection 400/230 VAC, 16A

OPTIMIZE YOUR MECARING M WITH TOOLS FOR A WIDE RANGE OF SEALS

MECATOOL BL

- Available from 32 mm to 200 mm (inch sizes available)
- Sewer and Duct pipe seals, such as BL etc.
- Compresses the seal for inserting, needs low lubrication
- Pneumatic operation with one cylinder

MECATOOL DD

- Available from 40 mm to 160 mm (also inch sizes)
- Sewer pipe seals, such as HMS and DD types etc.
- Slides the seal through the cylindrical tool, needs lubrication
- Pneumatic operation with two cylinders

Ask for bigger diameters (up to 400 mm) for special solutions.

extron
architects of extrusion

Taluttatie 4
FI-37800 Akaa, Finland
tel. +358 40 172 7391
info@extron.fi